

GATE OPERATOR **MASTER**

20QRA 20QMA 20T

**230
400 V**

Up to
2000 kg

Speed
10,5 m/min



P-500MASTER20QRA

230 V sliding gate operator with encoder and limit switches, complete with electronic control unit and built-in 433,92 MHz rolling code radio receiver. Max. gate weight 2000 kg.

P-500MASTER20QMA

230 V sliding gate operator with encoder and magnetic limit switches, complete with electronic control unit and built-in 433,92 MHz rolling code radio receiver. Max. gate weight 2000 kg.

P-500MASTER20T

400 V three-phase sliding gate operator with encoder without electronic control unit. Max. gate weight 2000 kg.



**Accessories for
MASTER series**
Page 44



Further accessories:
Transmitters page 238
Photocells page 243
Flashing lights
page 246



AVAILABLE



MADE IN ITALY

FEATURES:

- commercial use
- for gates up to 2000 kg
- 230 V (P-500MASTER20QRA/QMA) and 400 V three-phase (P-500MASTER20T) gate operators
- optical encoder technology for obstacle detection
- electronic brake
- irreversible gate operator
- lever manual release mechanism

PROS:

- obstacle detection and crush prevention
- suitable for large sliding gates
- high torque and power thanks to the three-phase 400 V AC version (P-500MASTER20T)
- external emergency release available (optional, P/N P-650ESE02)



PROTECTED CONTROL UNIT

The electronic control unit is well protected from the outside within its plastic shell (P-500MASTER20QRA/QMA).



PRACTICAL

The manual release is easy, intuitive and protected by a personal key.



SAFETY

Optical encoder technology as standard to ensure constant and reliable control of any obstacle.



MAXIMUM POWER

Reliability, power and minimum dimensions are the characteristics that distinguish the gearmotors of the MASTER series.

Technical features	MASTER20QRA/QMA	MASTER20T
Power supply	230 V AC (50 - 60 Hz)	400 V AC (50 - 60 Hz)
Motor power supply	230 V AC	400 V AC
Open circuit voltage	3,4 A	3,7 A
Power rating	550 W	1000 W
Max. operating speed	10,5 m/min	10,5 m/min
Duty cycle	50 %	100 %
Operating temperature	-20° C ÷ +55° C	-20° C ÷ +55° C
Motor thermal protection	160°C	150°C
Degree of protection	IP 54	IP 54
Max. gate leaf weight	2000 kg	2000 kg
Max. weight cantilever gate leaf	1400 kg	1400 kg
Pinion module	4	4
Electronic control unit	K590M	D703M (external)

TECHNICAL DRAWINGS

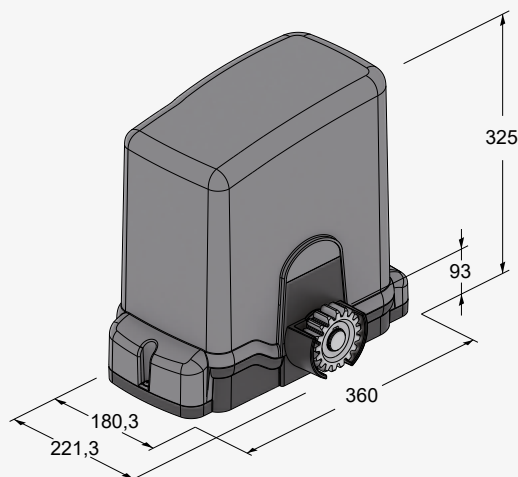

ACCESSORIES

COMMON ACCESSORIES



P-550CPMR
Adjustable counterplate from min. 65 mm to max 94 mm



P-550CPMR1
Adjustable counterplate from min. 124 to max 202 mm



K-550CPM
Counterplate



P-550CPM0020
Counterplate H 40 mm



P-400CFZ12
Steel rack 30x12, complete with screws (Module 4, max 2000 kg) Pack of 4 m



P-400CFZ22
Steel rack 22x22 (Module 4, max 3000 kg) 2 meter sections. Pack of 4 m



P-400FI
Adjustable hydraulic brake for sliding gates on a slope



P-400VSF20
Screws and brackets for P-400CFZ22 (40 units per pcs)



M-ING0MSTZ12
Pinion module 6



P-700BAP4
Gate stopper with spring



P-900TWM
Master receiver for central interface (manages up to max. 4 TWCs).



P-900BSD15
Deformable safety edge kit $l = 1,5$ m



P-900TWC
Battery-powered wireless slave transmitter for mobile/fixed sensitive edge (manages up to max. 2 sensitive edges per TWC).



P-900OPTIC
Set of infrared safety photocells, 12/24 V, surface mount, beam alignment adjustable up to 15°, up to 20 m range



P-650ESE02
External emergency release device (flush-mounted) with tamper-proof housing and 4 m cable



P-900T-COMM
Interface for connecting 2 opposite sliding gate automation in master/slave mode (**P-500MASTER20T excluded**)



C-TARG
Aluminium CE mark label, self adhesive



P-250T-WIFI
Device for Wi-Fi connection 2,4 GHz to allow the smartphone to remotely control and program the control units via TauApp. (**P-500MASTER20T excluded**)

ACCESSORIES FOR 18/24 VOLT



K-200KB4
Battery charger and backup battery kit



P-500MASTERKITFC
Electromechanical limit switches kit for MASTER.

NEW

ACCESSORIES FOR 400 VOLT (MASTER20T)



P-600D703
230/400 V electronic control unit for one gate operator with electrical brake (P-500MASTER20T)



P-900VLED-AT
230 V AC white led flashing light



P-250RXSM2
Self-learning, two-channel, 433,92 MHz plug-in radio receiver. Accepts up to 14 rolling code transmitters



P-750COL
Control unit mounting post

CHAIN VERSION

Upon request, the MASTER gearmotor is available with the pinion for chain transmission.

120 VOLT VERSION



AVAILABLE

Upon request, the MASTER gearmotor is also available in the 120 Volt version for foreign markets

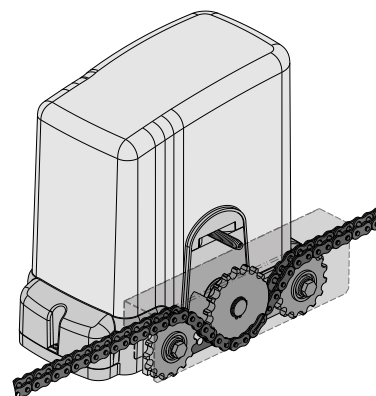

Use and maintenance manuals



MASTER



K130MA



K590M



D703