

# TECHNICAL INSTALLATION MANUAL

## MOTOREDUCER FOR SLIDING GATES

# SIMPLY



**WARNING!!** Before installing, thoroughly read this manual that is an integral part of the pack



Our products if installed by qualified personnel capable to evaluate risks, comply with norms UNI EN 12453, EN 12445



The CE mark conforms to European directive EEC 89/336 + 92/31 + 93/68 D.L. 04/12/1992 N. 476.

# INDEX

	Pag.
PACKING CONTENTS .....	2
VIEW OF TYPICAL AUTOMATION AND NAMES OF COMPONENTS .....	3
TECHNICAL DATA.....	3
DIMENSIONS .....	4
TYPICAL CONNECTION AND CABLE SECTION.....	4
CONSIDERATIONS FOR INSTALLATION.....	5
INSTALLATION.....	6
TROUBLESHOOTING.....	7
SAFETY PRECAUTIONS .....	8

## PACKING CONTENTS

1- GEARED MOTOR



1- LIMIT SWITCH ACCESSORIES



1- PAIR OF UNLOCKING KEYS



1- CONDENSER (230Vca)

## VIEW OF TYPICAL AUTOMATION AND NAMES OF COMPONENTS

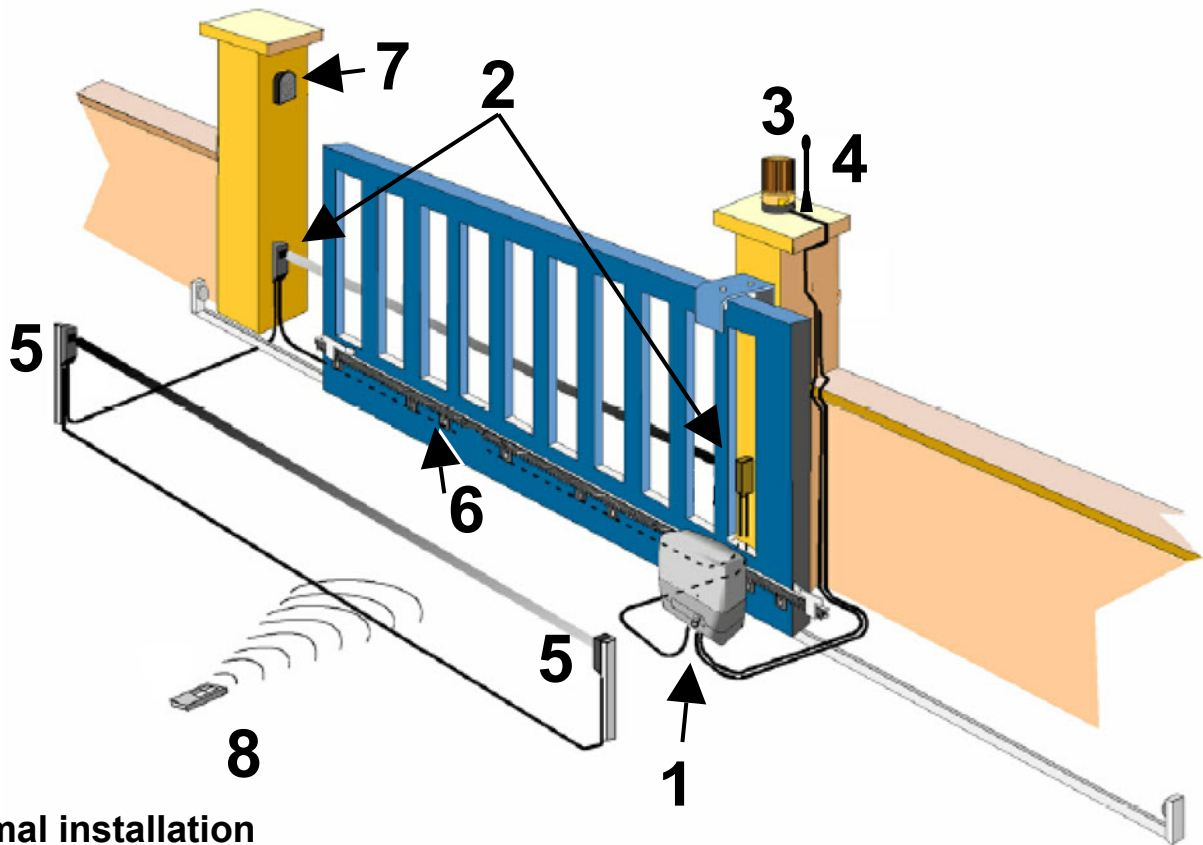

### Optimal installation

- |                                    |                       |
|------------------------------------|-----------------------|
| 1- Motor with on-board electronics | 5- Internal photocell |
| 2- External photocell              | 6- Rack               |
| 3- Flashing warning light          | 7- Key-switch         |
| 4- Antenna                         | 8- Remote control     |

### TECHNICAL DATA

	230V	24V	
Max. weight of gate	600 Kg	350 / 600 Kg	
Motors power supply	230 Vac	24 Vdc	
Motor current input	1.3 A	3 A	
Motor power	250 W	50 W	
Motor RPM	1400	1800	1800 Encoder
Condenser	12,5 $\mu$ F	/	
Mechanical unlock for emergency manoeuvre	With key		
Working temperature	-20° C / +55° C		
Weight	8 Kg		
Protection rating	IP 44		
Opening time	10 mt min	12mt min	
Limit switch	Electromechanical		

## DIMENSIONS

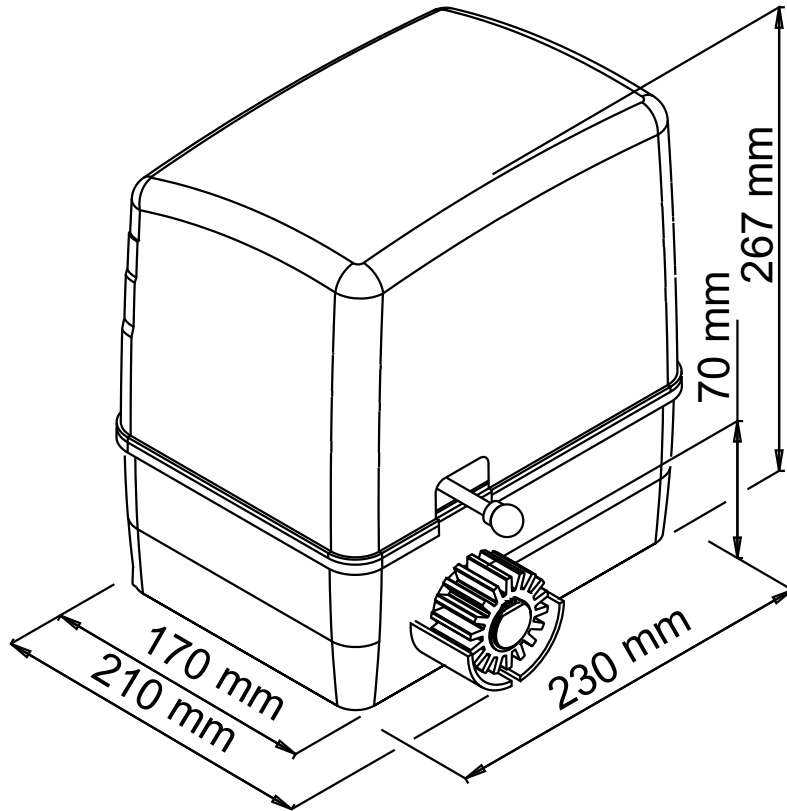

## TYPICAL CONNECTION AND CABLE SECTION

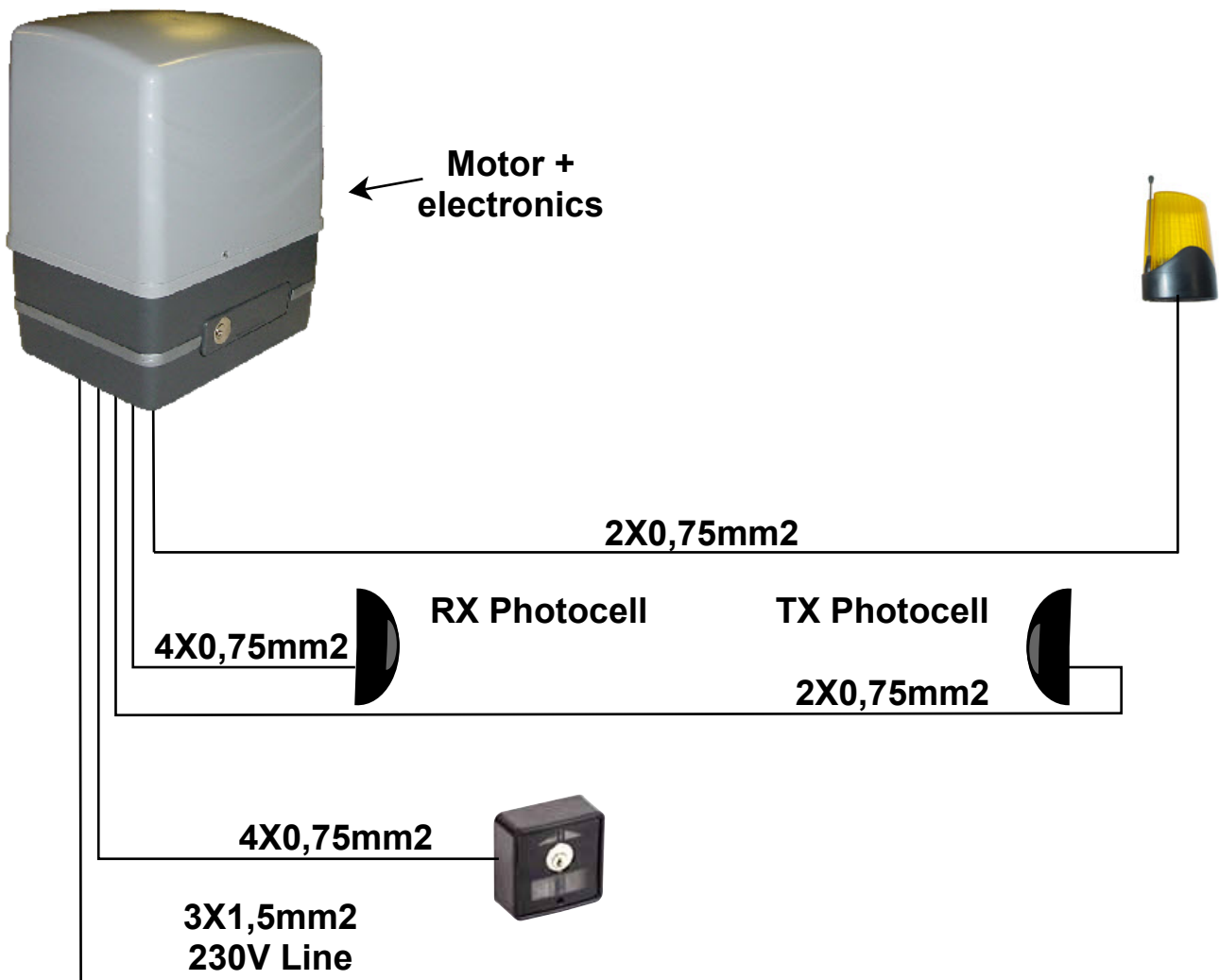

## CONSIDERATIONS FOR INSTALLATION

- The installation and testing operations must be performed solely by qualified personnel in order to guarantee the proper and safe operation of the automatic gate.
- The company declines any responsibility for damage caused by incorrect installations due to incompetence and/or negligence.
- Also check that the runner on the ground ( **Fig. 1** ) is not deformed, is perfectly level and that the mechanical stop is present on opening ( **Fig. 2** ) in order to **prevent** the gate from going beyond the upper runners ( **Fig. 3** )

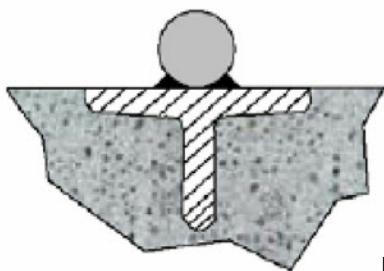
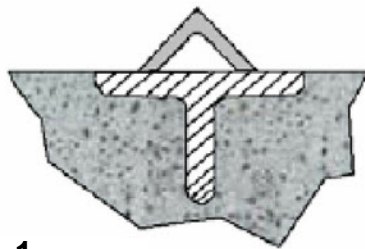

Fig. 1

Rounded section



Corner section

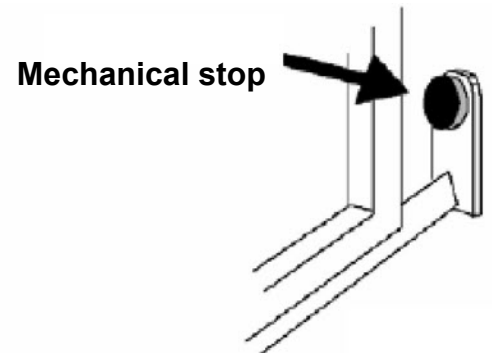

Fig. 2

- Check the upper runner ( **see Fig. 3** ) is firm and the gate slides freely.

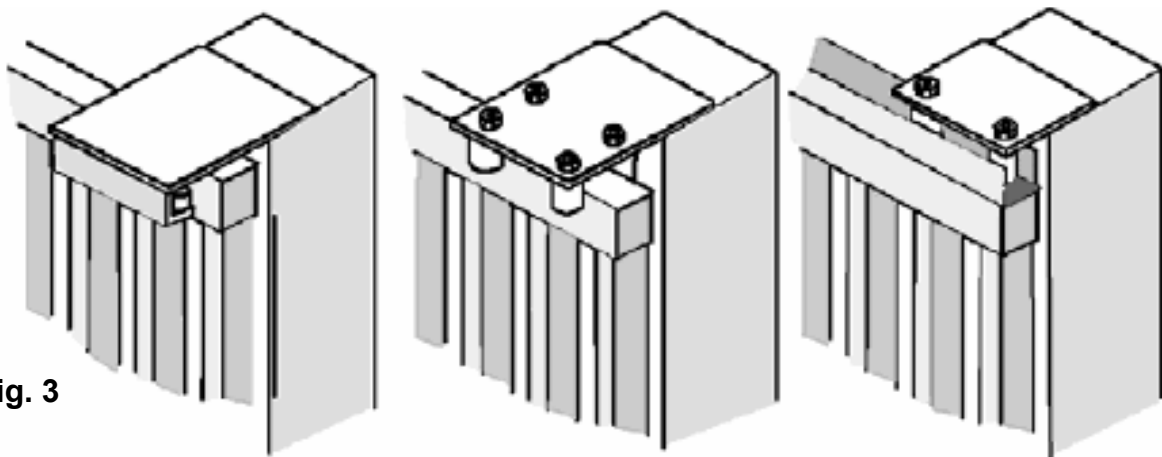

Fig. 3

- Check that the wheels ( **Fig. 4** ) used are suitable for the type of runner on the ground

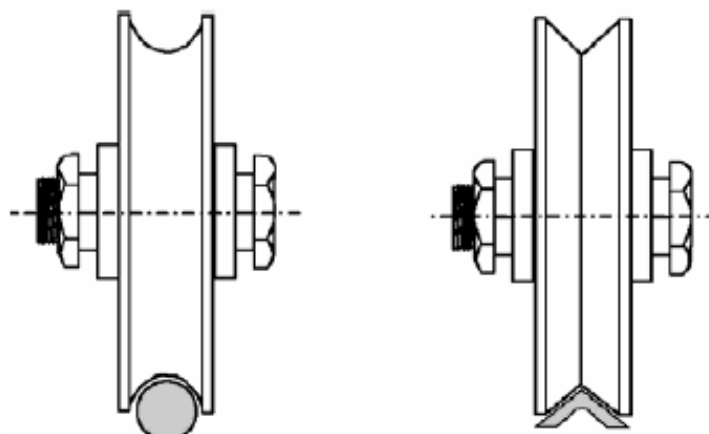
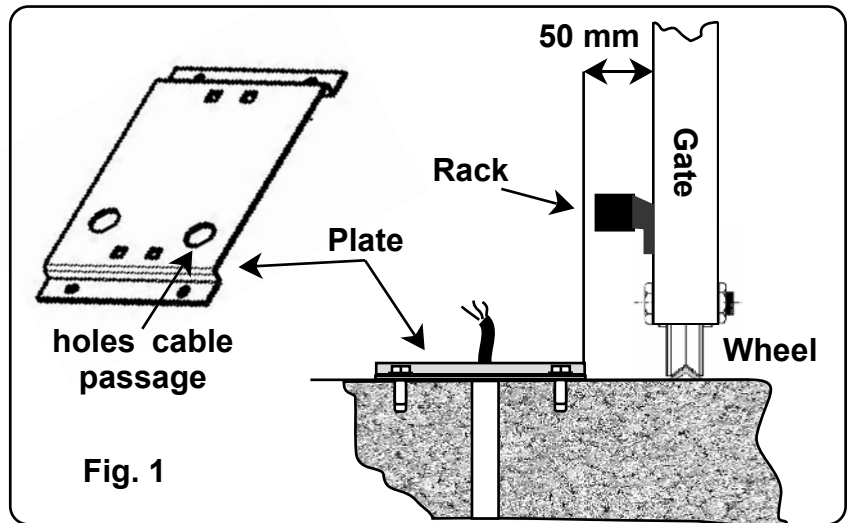

Fig. 4

# INSTALLATION

Position the plate provided (**Fig. 1**) **50 mm** from the edge of the gate and perfectly square at an angle of  $90^\circ$ .

Before fastening the plate with cement, dowels or other means, thread the cable sheath(s) through the prepared holes.



Position the operator and fasten it with the bolts provided. **A** (**Fig.2**).

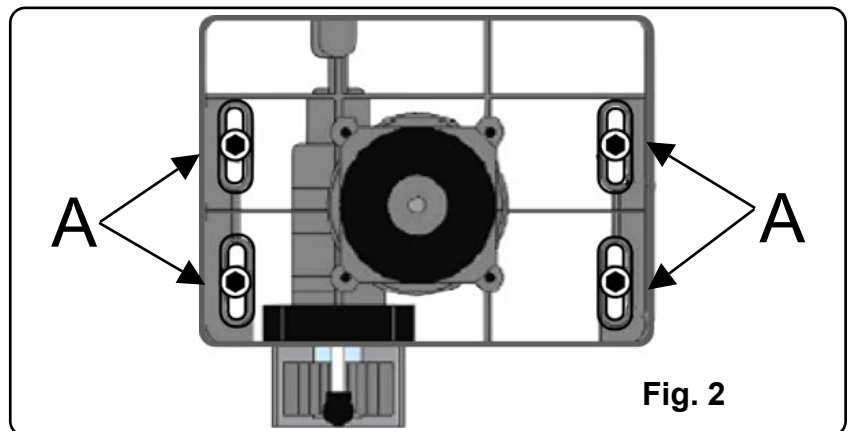

Fasten the rack to the gate firmly, leaving a distance of between 2 and 3 mm from the motor pinion (**Fig.3**).

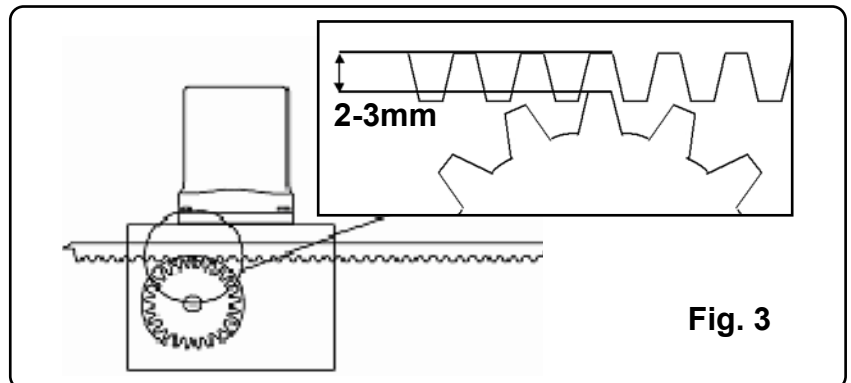

Fasten the limit stop plates (Cams **G**) of the motor on the rack, (**Fig. 4**)

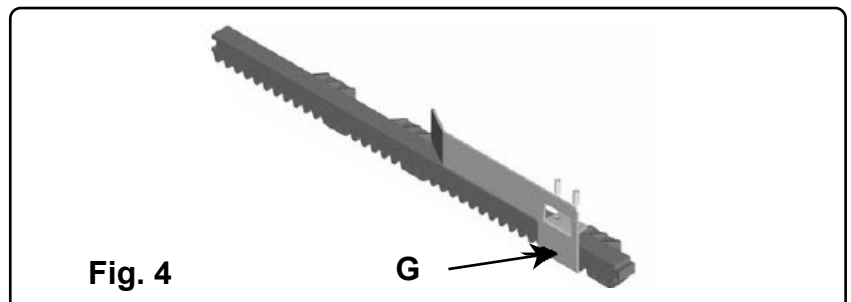

## Emergency release

1. Insert the key provided into the appropriate cylinder and turn the key.
2. Pull the lever until it stops

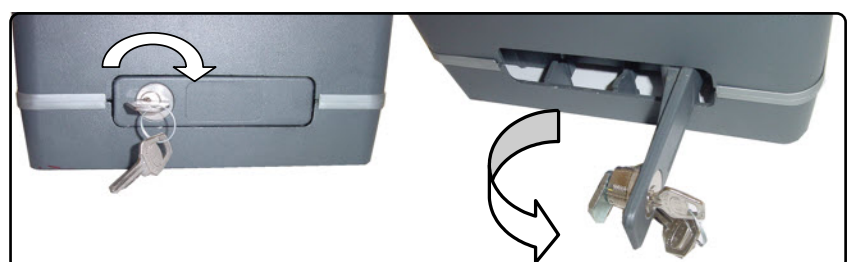

## TROUBLESHOOTING

PROBLEM	PROBABLE CAUSE	SOLUTION
On giving a command with the remote control or with the key-switch, the gate doesn't open or the motor doesn't start	230 volt mains voltage absent	Check master switch
	Emergency STOP present	Check for any STOP selectors or commands. If not used, check jumper on STOP contact input on the control board
	Fuse blown	Replace with one of same value.
	Power cable of motor or motors not connected or faulty.	Connect the cable to appropriate terminal or replace.
	The photocell is not functioning or the beam is interrupted	Check the connection, remove any obstacle across the beam
On giving a command with the remote control, the gate doesn't open but works with the key command	The remote control has not been memorised or the battery is flat	Carry out the remote control learning procedure on the radio receiver or replace the battery with a new one..
The gate starts, but stops immediately	The force of the motor or motors is insufficient	Modify the value with the FORCE trimmer on the control unit

**N.B. - If the problem persists, contact your Retailer or the nearest Service Centre**

All products are guaranteed for 2 years, as per the date on the invoice or on the receipt.

The warranty also does not include: failures or damages caused by faults of the electrical system and/or carelessness, negligence or inadequacy of the installation to the use for which it is intended and in any case from abnormal use; failures or damages due to tampering by unauthorized personnel or the use of components not attributable to the manufacturer and/or non-original spare parts; defects caused by chemical agents, external bodies or atmospheric and/or natural phenomena in general; failures or damages caused by incorrect installation of the Products according to the rule of art, safety and conformity of use expressly indicated in the technical documentation of the same Products; the consumables; interventions for checks and assessments of any flaws or defects then not found; compensations for the period of inactivity of the system where the Products are installed.



## **SAFETY PRECAUTIONS**

These warnings are an essential, integral part of the product and must be given to the user. They provide important indications on the installation, use and maintenance and must be read carefully. This form must be preserved and passed on to subsequent users of the system. The incorrect installation or improper use of the product may be dangerous.

## **INSTALLATION INSTRUCTIONS**

- The installation must be performed by professionally skilled personnel and in compliance with current local, state, national and European legislation.
- Before beginning the installation, check the integrity of the product.
- The laying of cables, electrical connections and adjustments must be workmanlike performed.
- The packing materials (cardboard, plastic, polystyrene, etc.) are a potential hazard and should be disposed of correctly and not left within reach of children.
- Do not install the product in potentially explosive environments or environments disturbed by electromagnetic fields. The presence of inflammable gases or fumes is a grave danger to safety.
- Set up a safety device for overvoltage, a disconnecting and/or differential switch suitable for the product and conforming to current standards.
- The manufacturer declines any and all responsibility for product integrity, safety and operation in the event incompatible devices and/or components are installed.
- Solely original spare parts should be used for repairs and replacements.
- The installer must provide all the information relating to the operation, maintenance and use of the individual parts, components and system as a whole.

## **WARNINGS FOR THE USER**

- Read the instructions and enclosed documentation carefully.
- The product must be used for the express purpose for which it was designed. Any other use is considered improper and therefore hazardous. In addition, the information given in this document and in the enclosed documentation may be subject to modifications without prior notice. It is given as an indication only for product application. The company declines any responsibility for the above.
- Keep products, devices, documentation and anything else provided out of reach of children. In the event of maintenance, cleaning, breakdown or faulty operation of the product, cut off the power and do not attempt to operate on the product. Contact solely the professionally skilled personnel responsible for these operations. Failure to adhere to the above indications may be dangerous.

**The data and images are for guidance only**

**VDS reserves the right to change at any time characteristics of the products described in its sole discretion, without notice.**



**Via Circolare p.i.p. N° 10  
65010 Santa Teresa di Spoltore (PE) - ITALY  
Tel. +39 085 4971946 - FAX +39 085 4973849  
www.vdsautomation.com - info@vdsautomation.it**